



## The XML interoperability and the Polish Energy Market needs

Dariusz Bober<sup>\*</sup>

*Institute of Computer Science, Lublin University of Technology,  
Nadbystrzycka 36B, 20-618 Lublin, Poland*

### Abstract

There are only a few months from the Polish Energy Market opening. This subject, especially in the face of the last political confusion about the natural gas delivery has been a topic of many publications and speeches of politicians during the last months. But, besides this medial outcry, well working and flexible Polish Energy Market, as it is planned, is a very complex problem to solve, and there are many tasks to be done before the 1 July 2007 [1]. In this work the author focuses on the aspects of information flow coordination between the end-users (consumers of energy) and other participants (generators, transmitters, wholesale resellers – the players) of the Polish Energy System. In this article there will be described a concept of two direct electronic data exchange between the energy measure unit located at let's say "Kowalsky's" house, and any other computer systems of the player.

### 1. Introduction

To find the best solution of such a complex organism as the energy market it, is good to study the experience of those who have done it before. The Energy Market in Germany was welcomed very enthusiastically at first, next customers have realized that they had signed contracts with an "anonymous" power station which offered the cheapest energy, but in consequence, they did not know who is responsible for supply of energy (where to call), they had new invoices for energy, new bank accounts, etc. The customers in Germany estimated that they had saved due to this change only a few dozen euros. However, there was much confusion with the energy delivery change.

The conclusion is that the Polish Energy Market needs some standardization processes for financial documents exchange. Here it is good to think about electronic documents exchange.

Preparing the financial mechanisms of the Polish Energy Market it could be helpful to study the Canadian experience [2]. There in May 2002, in one of the provinces – the Ontario's electricity sector was opened to both wholesale and retail price competition. The wholesale consumers may enter directly bilateral

---

<sup>\*</sup>E-mail address: [borowik@pluton.pol.lublin.pl](mailto:borowik@pluton.pol.lublin.pl)

physical or financial contracts of wholesale sellers and generators. The retail consumers were free to enter into fixed-price contracts with retail intermediaries or they could stay with the present supplier. Almost one million of the province's 4.4 million retail electricity customers chose the second way signed the out fixed-price contracts. When the prices of electricity began to increase rapidly, from the average hourly wholesale 3.01 cents per kilowatt hour (kWh) in May up to \$1.03 per kWh in September, the increasing criticism of the society led the provincial government to freeze retail prices. The government made the frozen retail rate retroactive to market opening and it refunded any amount over 4.3 cents per kWh already paid by customers. In consequence the retail market was closed.

The conclusion can be drawn that there should be prepared appropriate methods of evaluation valuation of customers' energy consumption, which on one hand will allow to implement free-market roles but from on the other hand, these methods ought to point to financial condition of the society. The electricity can not become the privilege of the rich – it is good to think about diversification of energy suppliers for each “Kowalsky” and in this way it is necessary to prepare appropriate methods of energy “packets” addressing and monitoring the limits of energy consumption by retail customers.

## **2. Concept of model of bidirectional electronic data interchange**

Electronic data interchange (EDI) becomes significant standard of business data interchange between cooperating partners. At first, being accessible only for the biggest companies because of its price, after founding alternative technologies eg. XML (eXtensible Markup Language), EDI provides the possibility for costs reduction, saving time and a new way for business partners founding [3]. The Xml technology is a well adoptive language to the data descript in e-business aand other domains of electronic data interchange activity [4]. The author has its own experience in electronic business data interchange with XML technology using, its authorship module prepared for one of Lublin's companies and presented at the IBIZA conference in 2004 [5]. Owing to observations of rapid increase of the electronic data interchange significance and its ability of interoperation of the computer systems of cooperating business partners, the author suggests that it is important to implement some similar solutions for the Polish energy market. Although the necessity of electronic measure of power consumption is taken into consideration [6,7], but as the author found in literature, it is only one way. In the author's opinion it will not be enough for the long time, and why not use the existing possibility to exchange the data in both ways? Possible cost of that functionality (see fig. 1) could be lower than the presumable facilities.

The basic concept of the proposed subsystem was presented in [8,9], here the author concentrates on the process of modelling and the data describing language.

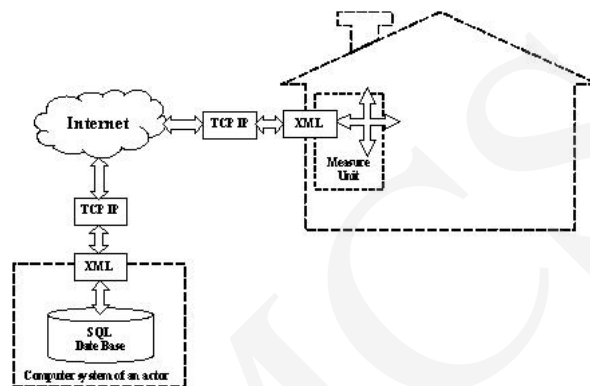

Fig. 1. Conceptual schema of electronic data interchange for the Energy Market

A model of that bidirectional communication between the Players of the Market and the final consumers has to get some simplifications. The first assumption is that there exists the internet connection in both localizations of energy-business transaction. As it could be read at [6] that functionality is considered the necessity of the Market accomplishment.

The second assumption is: it is possible to prepare a functionality of a measure unit to read and process electronic information received by the unit, and to address and send electronic information back. This assumption is also possible so there are now exploited some measure units which process information about quantity of power use and cut the power when it exceeds the bought limit (prepaid system). If these units can process it, they will process some others after upgrade of their firmware (sometimes hardware, too).

The third assumption is: the end users (the consumers) have ability to turn off, or turn on some house equipment, as the reply to the information received to their measure units, possibly the answer (turn off/on action) is automated.

At the current stage of study no specific equipment is considered, its essence of bidirectional communication is being specified.

One of the roles of electrical system stability is the balance of power, described by the equation:

$$P_{de} + P_w - P_o - \Delta P_s = 0, \quad (1)$$

where  $P_{de}$  power delivered by generators,  $P_w$  power exchanged with neighbour's systems,  $P_o$  power consumed by end users,  $\Delta P_s$  – power lost.

The most unpredictable part of equation (1) is the level of power consumption and each change in its volume has to be balanced by modifiers of power generated or exchanged with other systems – it costs. There are a lot of

parameters being taken into power demand prognoses: historical values, weather, holidays, even for common name days and TV-set programs are taken a special margin (see table 1).

To reduce a loss, the transmitters and distributors have to prepare prognoses of power demand curve (see fig. 2).

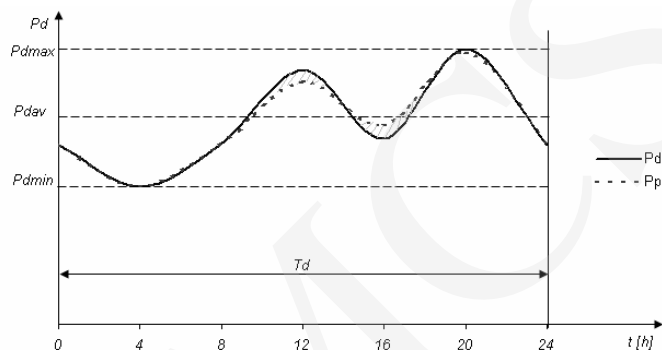

Fig. 2. Example of real  $P_{do}$  and prognoses  $P_{pr}$  power demand curves

The  $S$  field drawn by the difference of curves, represents a financial loss of a distributor, and in consequence the same loss for consumer (who pays for distributor’s mistakes). For their own business the field  $S$  should be minimized.

$$S = k \int_{t=0}^{T_d} p_u \cdot (P_{pr} - P_{do}) dt, \quad (2)$$

where  $p_u$  price per unit of energy at a point of time,  $k$  – direction parameter of relative deviation.

Currently, there are laboratories for the best prediction of  $P_{pr}$  power. The real consumed power ( $P_{do}$ ) is taken as it is, with no possibility of flexible interaction. The only possible interaction “cut off the power” is rather used as the last resort, not as a flexible tool.

Let’s declare the function  $P_{do}(EDI)$  which represents the actual power consumption, but depends on the decision of consumers being taken as a reply to the electronic information  $EDI$  delivered to their measure units. Also, as stated in [6], the electronic information about actual consumption of energy per time could improve the correctness of power demand prognoses. This way, it is also possibly to declare the function  $P_{pr}(EDI)$  which represents influence of electronic remote power consumption measure on prognoses of power demand elaboration.

Including this function into equation (3), there could be prepared the first model of bidirectional electronic data interchange for the Polish Energy Market:

$$S = k \int_{t=0}^{T_d} p_u \cdot (P_{pr}(EDI) - P_{do}(EDI)) dt. \quad (3)$$

To prove usefulness of interest in the function  $P_{do}(EDI)$  control, there is presented some data in Table 1.

Table 1. Selected data from the Polish Electro Energy System

Specification		Unit	Value
Power of the biggest waterfall generator <sup>(a)</sup>		MW	680
Power of the biggest block of power plants <sup>(a)</sup>		MW	<b>500</b>
Poland <sup>(b)</sup>	Power consumption in households	GWh	22 052
	Quantity of households	[thousand]	12 596
Lublin <sup>(b)</sup>	Power consumption in households	GWh	103.12
	Quantity of households	[thousand]	359.3
The margin of daily prognosis of power demand for the country taken for the attractive TV programs <sup>(a)</sup>		MW	<b>100-400</b>

As presented, if the consumers only turn-off their TV-sets as the response to the information delivered to their meter units, power saved for the whole country will be compared to that power of one block of power plant.

The conclusion is that exists some safe margin of power consumption to be interoperated by logical systems of an overriding player (distributor). The margin could be safe because the consequences of that interoperation (consumer could not watch his favourite TV program) are better for him (he could go for a walk), than for instance: the total blackout as extreme response to too high power consumption. That is of course an extremity, rather not imposing threat to the Polish consumer Poland has got a surplus of power installed to the system [12].

The bidirectional model of electronic data interchanging allows to implement interoperability into the Polish energy market roles.

To implement full interoperability into electronic cooperation between the Players of Polish Energy Market and The End-Consumers, it is necessary to prepare a language for communication, formats of data and standards of documents. Here functionality of the XML technology seems to be the most appropriate to the market needs.

### 3. XML technology in the Polish Energy Market service – concept

“You can’t control what you can’t measure” by Robert de Marco

The data having to be interchanged have two types of functionality: **to inform** and **to control**. The informing data types are:

- level of power consumption in the served date and time period, possibly shorter than one hour,

- quality of power (possible indices of quality: *cosphi*, *time and frequency of turning off the power*, *higher harmonic*, others available to measure by meters).

In these two points the functionality of the electronic interchange data is similar to the expected one on the current level of planned data remote reading by [6]. The implementation of two direct data interchange increases the range of information functionality. Both partners of two sides of electro-transaction business process, a consumer and a supplier are interested in getting more information about history of power consumption. A supplier is interested in:

- getting information about quantity of power to be used on prepaid meters,
- sending information about planned turn-off the power, date and times,
- sending information about possible promotions in power sells,
- sending a notice to pay arrears,
- etc.

The consumer is interested in:

- getting information about current power consumption and a level of its costs,
- getting an invoice for power consumption,
- sending a mail for service,
- etc.

The functionality of control of two directional methods of data interchange looks more interesting, here possible data to be interchanged are:

- a command sent to consumer equipment,
- a replay from measure instrument about effects of the command.

These two functions give to suppliers a new, never possible before, tool to semi linear power demand control. In consequence, the cost of mistakes of power demand prognoses will decrease – the prognoses could be more correct.

The XML allows to diverse the equipment (meter units) used for the project realization. It is not necessary to use identical equipment for each end-users (the next free market role). The meter units may have implemented various functionality, a part of them could only display the message on its LCD monitor, the others could process more, for instance to initiate some automats connected to their outputs. The XML technology allows to send to both of these groups the same electronic message, an interpreter (parser) will find in the message in information it could process, a simple tag which could not be processed will be passed over by interpreter (see fig. 3).

```

<?xml version="1.0" ?>
- <document>
- <head>
  <id>x0aj3kds</id>
  <date_time>20060209_1200</date_time>
- <lives>
  <keep>3</keep>
  <step>min</step>
</lives>
</head>
- <body>
- <action>
  <control>reduce</control>
  <degree>2</degree>
</action>
<message>Have a nice day</message>
</body>
</document>

<?xml version="1.0" ?>
- <document>
- <head>
  <id>x0aj3kds</id>
  <date_time>20060209_1200</date_time>
- <lives>
  <keep>3</keep>
  <step>min</step>
</lives>
</head>
- <body>
+ <action>
  <message>Have a nice day</message>
</body>
</document>

```

Fig. 3. Example of the same information read by two different meter units, -project

Here the XML flexibility gives almost unlimited possibilities for data interchange even the one which does not exist at the moment of the scheme of exchanged data projecting [10], but, of course, limited by technical ability of used measure instruments. Fortunately, the functionality of this latter still increases and what's more, it will be improved when the demand appears. Let it be solved for the market mechanisms.

It is necessary to say here about possible dangers of that solution. The first one is the dominant position of the supplier which would decrease or increase the power demand only for its own financial profit. To counteract, there have to be prepared appropriate contracts which will secure the consumer rights.

The second danger is possibility of an interference of the third person – an aggressor – the data are interchanged via the internet. An aggressor would to prepare some attack at the consumer goods by alarm system inactivation with “power disinformation”. But here are appropriate methods to make the EDI transactions safe, authorized and confidential [11].

#### 4. Some economy index of bidirectional interoperability

Beginning with equation (3) we may improve that the  $S$  function of loss to be minimized when  $P_{pr}(EDI)$  and  $P_{do}(EDI)$  functions get identical values at the same points of time:

$$S(t) = 0 \Leftrightarrow P_{pr}(t, EDI) = P_{do}(t, EDI). \quad (4)$$

Equation (4) describes an ideal situation, but as presented at the bottom, there exists some margin in  $P_{do}$  real power consumption which allows to get it closer to the  $P_{pr}$  consumption prognosis function. At that margin the  $P_{pr}$  function behaves static (it is too late to change the contracted power), but there is still some time to impress consumers' behavior and in this way to minimize the financial consequences of inaccurate prognosis.

Then equation (4) takes the form:

$$S(t) \rightarrow 0 \Leftrightarrow P_{do}(t, EDI) \rightarrow P_{pr}(t). \tag{5}$$

Let:

$$\Delta P_{mi}(t, EDI) = P_{pr}(t) - P_{do}(t, EDI). \tag{6}$$

Then:

$$S(t) \rightarrow 0 \Leftrightarrow \Delta P_{mi}(t, EDI) \rightarrow 0. \tag{7}$$

Table 2 present real one day data (column “b”) from one of the Polish distributors. There are presented also the balance market prices [14] of electric energy per unit (columns “c,d,e”) in the corresponding points of time.

Table 2. Analysis of one day inaccuracy prognosis of demand power, giving possibility of EDI influence on reduction of inaccuracy cost

Time	$\Delta P_{mi}^{(a)}$	CRO <sup>(b)</sup>	CRO <sub>Z</sub> <sup>(b)</sup>	CRO <sub>S</sub> <sup>(b)</sup>	Amount of balance Power	Amount of power if consumed	Cost of inaccuracy prognosis	EDI message	Margin of economy justified price reduction	Possible saved money for future clear accounts
[hour]	[MWh]	[PLN/MW]	[PLN/MW]	[PLN/MW]	[PLN]	[PLN]	[PLN]	-	[%]	[PLN]
a	b	c	d	e	f=b*d or f=b*e	g= b *c	h=-f-g or h=-f+g	i	j=h/g	k=-h
1	-12.862	100.00	75.96	215.16	-977.00	1,286.20	-309.20	↗	-24.0%	--
2	-2.079	88.91	74.52	213.08	-154.93	184.84	-29.92	↗	-16.2%	--
3	-3.824	85.75	74.83	214.28	-286.15	327.91	-41.76	↗	-12.7%	--
4	-3.482	89.09	75.24	213.68	-261.99	310.21	-48.23	↗	-15.5%	--
5	0.367	84.06	73.81	212.92	78.14	30.85	-47.29	↘	--	47.3
6	0.906	83.14	73.34	213.95	193.84	75.32	-118.51	↘	--	118.5
7	-11.708	95.20	75.42	212.75	-883.02	1,114.60	-231.58	↗	-20.8%	--
8	-9.525	100.00	79.71	227.88	-759.24	952.50	-193.26	↗	-20.3%	--
9	-2.649	105.00	82.73	231.28	-219.15	278.15	-58.99	↗	-21.2%	--
10	3.081	110.82	85.77	240.72	741.66	341.44	-400.22	↘	--	400.2
11	6.122	101.21	86.63	215.79	1,321.07	619.61	-701.46	↘	--	701.5
12	-17.519	101.25	88.84	213.55	-1,556.39	1,773.80	-217.41	↗	-12.3%	--
13	-15.753	106.71	87.81	212.74	-1,383.27	1,681.00	-297.73	↗	-17.7%	--
14	-17.090	101.30	90.09	195.94	-1,539.64	1,731.22	-191.58	↗	-11.1%	--
15	-11.084	101.21	91.37	254.78	-1,012.75	1,121.81	-109.07	↗	-9.7%	--
16	-2.039	101.21	91.28	257.03	-186.12	206.37	-20.25	↗	-9.8%	--
17	-17.157	101.21	91.86	266.07	-1,576.04	1,736.46	-160.42	↗	-9.2%	--
18	-22.553	105.00	92.52	262.64	-2,086.60	2,368.07	-281.46	↗	-11.9%	--
19	-8.921	101.05	89.44	243.52	-797.89	901.47	-103.57	↗	-11.5%	--
20	-16.733	95.39	86.49	233.35	-1,447.24	1,596.16	-148.92	↗	-9.3%	--
21	-11.281	98.01	85.12	234.75	-960.24	1,105.65	-145.41	↗	-13.2%	--
22	2.058	100.36	85.09	230.95	475.30	206.54	-268.75	↘	--	268.8
23	-7.591	100.65	81.32	222.02	-617.30	764.03	-146.73	↗	-19.2%	--
24	-10.412	105.00	79.45	215.15	-827.23	1,093.26	-266.03	↗	-24.3%	--
Total	-191.728				-14,722.18	21,807.46	-4,537.77			1,536.24



Column “h” presents the cost of undelivered power to customers, diminished by the amount of resold power on the balance market, plus over contracted power consumption purchased on the same market.

Column “i” is an information and intention of this information possible to be sent to the consumers, as a part of proposed functionality of projected *XML(EDI)* methods of electronic data interchange.

The columns “j” and “k” present the expected margin of economy justified changes in the power consumed prices or in mechanisms of retail activity. These changes should be oriented towards both consumer’s and distributor’s business.

At the bottom of Table 2 total values of processed quantities are presented. As we can see the distributor gets back about 67% (14,722.18/21,807.46) of costs of not distributed power from the balance market.

Additionally, there is up to 30% (4,537.77/14,722.18) of this cost to get back by the *XML(EDI)* mechanism to encourage consumers to behave according to the information received by their meter units.

The data presented in this table include a small range of time to expect them to be in force in the whole spectrum of customers’ behaviour, but they show some ability, never available before of interoperation customers and other players of energy industry. Is it profitable? There are lots of parameters to be taken into consideration, but there are possible to be enumerated. The author is doing research in this field and is going to publish some results in next papers.

### **Conclusions**

There are a few reasons for the research in the presented field of implementation the interoperability for end-users of electro-industry system area:

The first one is predicted in connection with the necessity of real energy consumption account. In [6], it is stated one hour of energy consumption metering and in consequence, there is necessity of implementing technical solution for electronic data collection from each household installed measure units.

The second reason is created by the Energy Market itself, because we can tell about equality of access to the market if each of its participants has access to the information about its condition too. The information flow is the clue for the market success.

The interoperability of *XML* technology allows to implement some methods of multidimensional and dispersive energy consumption control.

Is it justified by economy? The first results presented in Tables 1 and 2 give the positive answer, but there are lots of parameters to be taken into the final clearing.

### References

- [1] *Prawo energetyczne*, Ustawa z dnia 10 kwietnia 1997 r. z późniejszymi zmianami. Stan prawny na 13 stycznia 2006 r., in Polish.
- [2] Trebilcock M., Hrab R., *Electricity Restructuring in Ontario*, Energy Journal, IAEE, Cleveland USA, 26(1) (2005) 123.
- [3] Muryjas P., Bober D. *ebXDI – technologia EDI za rozsądne pieniądze*, Wdrażanie i eksploatacja systemów informatycznych, PTI, Lublin, (2002) 85, in Polish.
- [4] Bober D., Łagód G. and Suchorab Z., *Using New Technologies of Computing In Sustainable Development*, In. Environmental Engineering Studies, Polish Research on the Way to the EU, Plenum/Kluwer, N.York, (2003) 377.
- [5] Bober D., *XML In Business tasks realisation*, Annales Informatica UMCS, Lublin, (2004) 357.
- [6] Gawin R., *Opomiarowanie odbiorców a liberalizacja rynku energii elektrycznej*, Biuletyn Urzędu Regulacji Energetyki nr 6, Warszawa, (2005), in Polish.
- [7] Topolski J., Begier P., *Poszukiwanie nowych rozwiązań modelu rynku energii elektrycznej*, Wokół Energetyki, Termedia, 8 (2005) 31, in Polish.
- [8] Bober D., *Projekt podsystemu informatycznego w zabezpieczeniach systemów energetycznych*, Współczesne Technologie Informatyczne, inżynieria oprogramowania, systemy baz danych, Mikom, Warszawa, (2005) 127, in Polish.
- [9] Bober D., *Conceptual Model of Informatic System of Control for The Electrical Industry*, International Workshop Control and Information Technology, Ostrava, Czech Republic, (2005) 151.
- [10] Bober D., Muryjas P., *Aspects of XML Technology in eBusiness Transactions*, 4th International conference of PHD students, Engineering Sciences I, University of Miskolc, Hungary, (2003) 275.
- [11] Bober D., Muryjas P., *The security of electronic data exchange in XML technology*, 3<sup>rd</sup> International conference of Computing Technologies in Economy, Science and Education, Svitaz, Ukraine, (2005), materials in editing.
- [12] Gładyś H., Malta R., *Praca elektrowni w systemie elektroenergetycznym*, WTN, Warszawa, (1999), in Polish.
- [13] Mały Rocznik Statystyczny Polski, (2004), in Polish, [www.stat.gov.pl/opracowania\\_zbiorcze/maly\\_rocznik\\_stat/2004/](http://www.stat.gov.pl/opracowania_zbiorcze/maly_rocznik_stat/2004/)
- [14] <http://www.cire.pl/GE/ceny/index.php>